	DATASHEET	Part No.
	90-Degree Hybrid Coupler	CXH 03 T 3337 AA

CUSTOMER : _____

DATA SHEET

Product Name : 90-Degree Hybrid Coupler

Part No : CXH 03 T 3337 AA

Customer Code :

	MAKER	Location	TEL.	ADDRESS
	Office(Korea) Manufacture	Incheon	TEL) 82-32-821-0363 FAX) 82-32-811-0283	(21629) 5BL-1Lot, Namdongsearo 380, Namdong-Gu, Incheon, KOREA
	Homepage(URL)	http://www.amotech.co.kr		

1. Parts description

1.1. Overview

The CXH Series is a low cost, low profile sub-miniature high performance 3 dB coupler in an easy to use surface mount package. LTCC (Low Temperature Co-fired Ceramic), high conductivity metal conductor (Ag), and gold (Au) plating enable the CXH Series to minimize insertion loss and improve durability for thermal stabilization and electricity. The CXH Series is offered in a variety of frequency bands compatible with various types of high frequency wireless systems.

1.2. Features

- 3300 ~ 3700MHz
- Mean Coupling 3dB
- Low Insertion Loss
- Surface mount type
- LTCC base (Er=4.6)
- RoHS Compliance (Pb Free)

1.3. Applications

- Balanced Amplifiers and Signal Distribution in Wireless Communications
- LTE, WiMax and WiBro
- Base station and Repeater



DATASHEET

Part No.

90-Degree Hybrid Coupler

CXH 03 T 3337 AA

2. Model and Lot Number description

2.1. Model

<u>CXH</u>	<u>03</u>	<u>T</u>	<u>3337</u>	<u>AA</u>
(1)	(2)	(3)	(4)	(5)

- (1) Series name
- (2) Coupling (dB) : Mean Coupling 3dB
- (3) Chip Size : "T" – 0805inch (2.0 x 1.2 mm)
- (4) Frequency Bandwidth: 3300MHz ~ 3700MHz
- (5) Design Code

3. Style and Dimension

3.1. Appearance and dimension

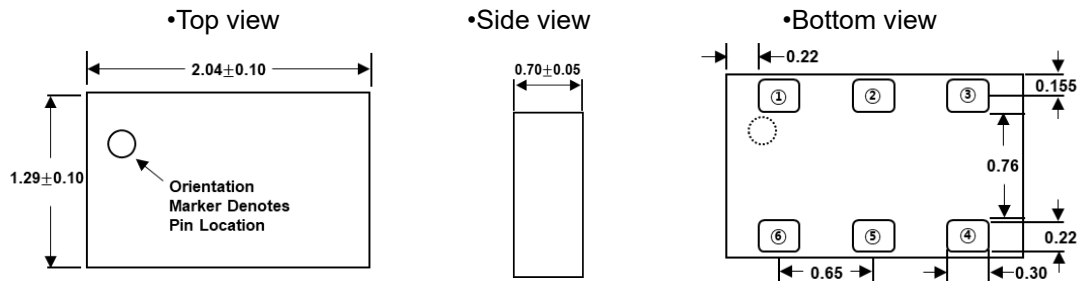

- Unit : mm
- Tolerances are Non-Cumulative

3.2. Pin Description

Pin	Case 1	Case 2	Case 3	Case 4
①	Input	Isolated	Direct	Coupled
②	GND	GND	GND	GND
③	Isolated	Input	Coupled	Direct
④	Direct	Coupled	Input	Isolated
⑤	GND	GND	GND	GND
⑥	Coupled	Direct	Isolated	Input

4. Specifications

4.1. Frequency characteristics

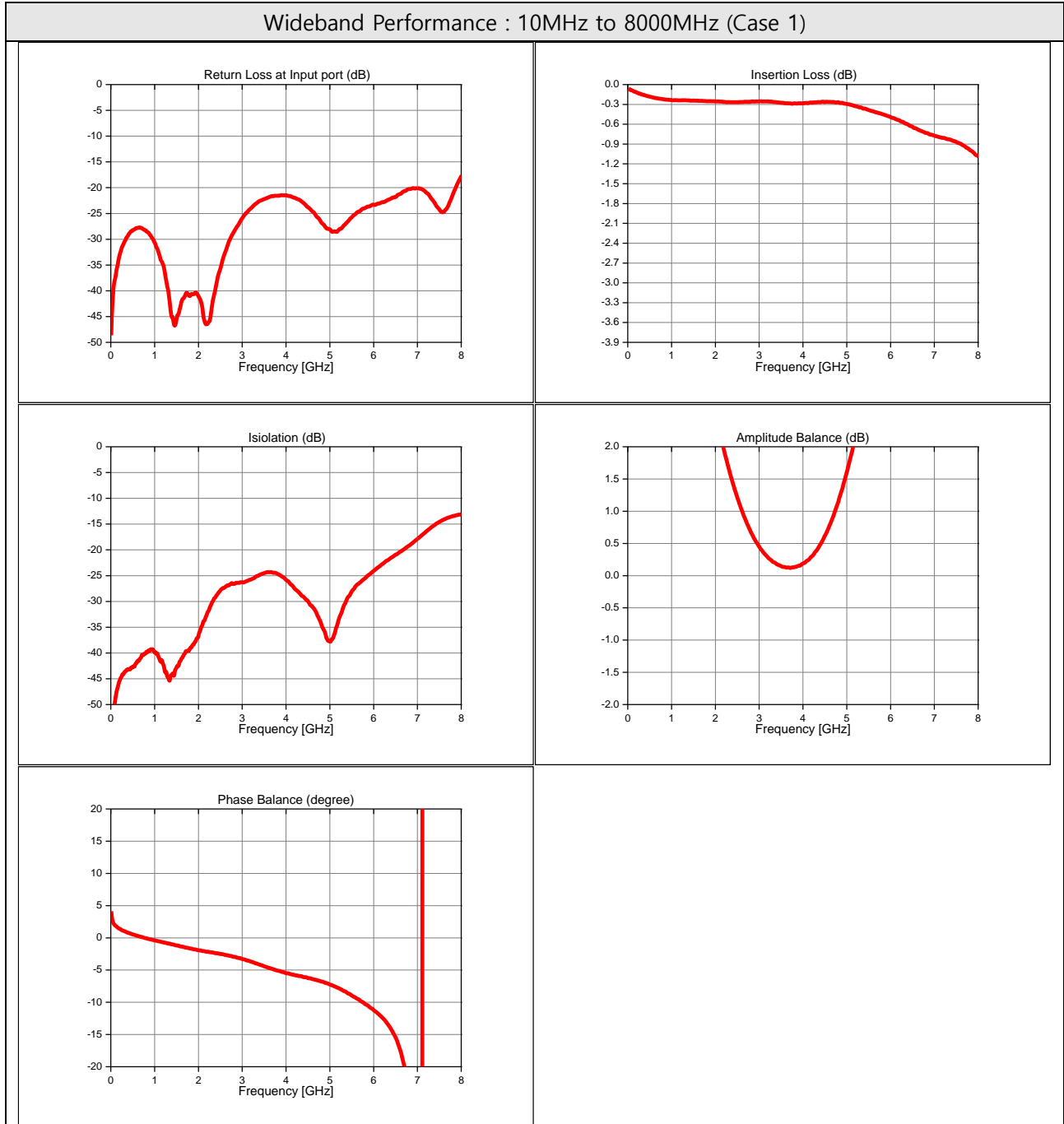

Typical Performance : 2800MHz to 4000MHz (Case 1)

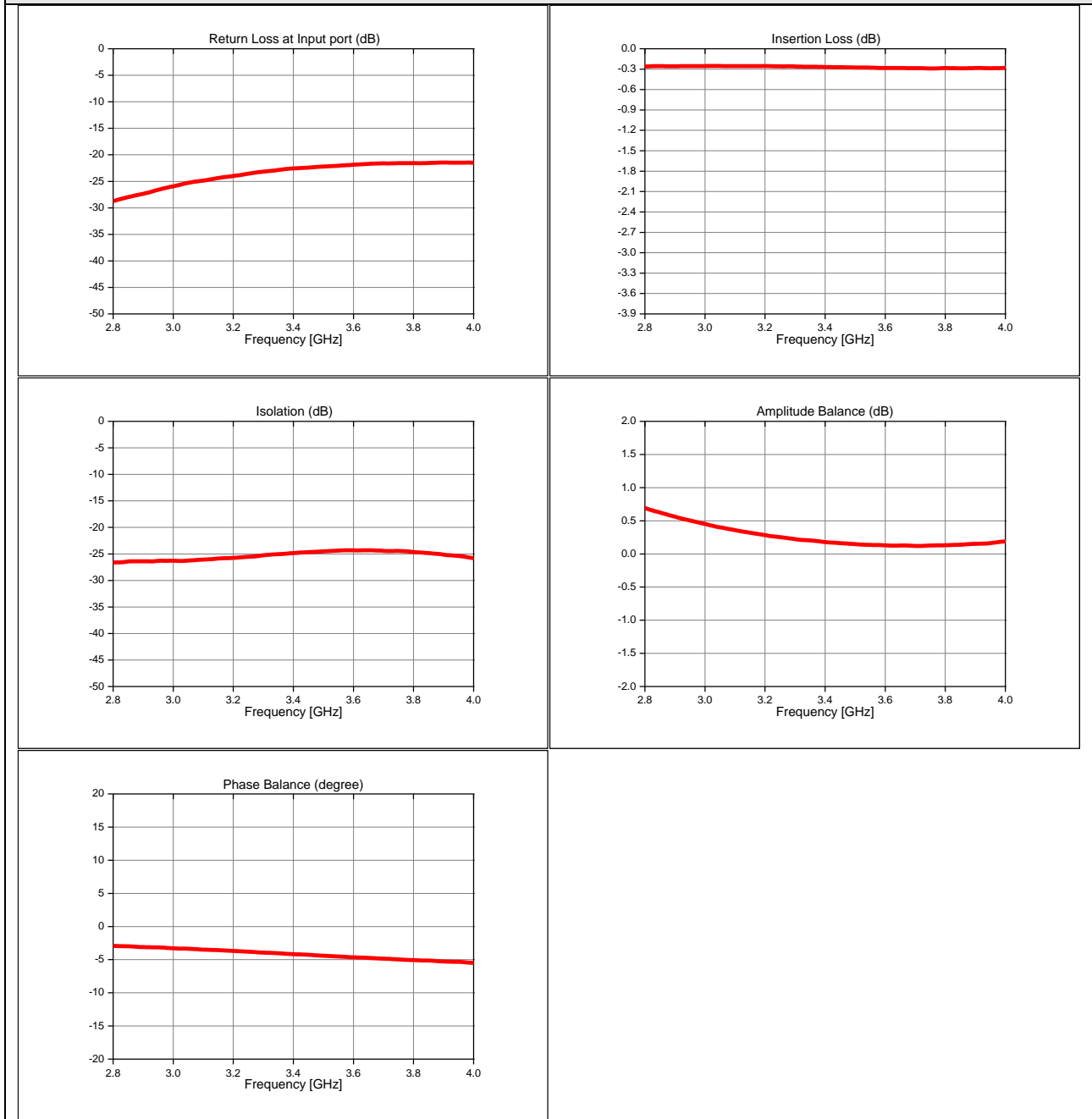

4.2. Electrical characteristics

Frequency Range (MHz)	Amplitude Balance Max.(dB)	Return Loss Min.(dB)	Insertion Loss Max.(dB)	Isolation Max.(dB)	Phase Balance (Degree)	Power Handling Max.(W)
3300 ~ 3700	±0.25	23	0.28	24	90±5.0	2
3300 ~ 3500	±0.25	21	0.27	24	90±5.0	2
3500 ~ 3700	±0.15	21	0.28	24	90±5.0	2

4.3. Definition of Measured Specifications

Parameter	Definition	Mathematical Representation
Coupling	At a given frequency coupling is the input power divided by the power at the coupled port. Coupling is the average values in the band.	$10\log (P_{cou} / P_{in})$
Return Loss	The impedance match of the coupler to a 50Ω System. Return Loss is an alternate mean to express VSWR.	$10\log (P_{in} / P_{back})$
Isolation	The input power divided by the power at the isolated port.	$10\log (P_{iso} / P_{in})$
Insertion Loss	The input power divided by the sum of the power at the two output port.	$10\log (P_{in} / (P_{in} + P_{out}))$
Amplitude Balance	The power at each output divided by the average power of the two outputs.	$10\log \left(\frac{P_{cou}}{\frac{P_{cou} + P_{out}}{2}} \right)$
Phase Balance	The difference in phase angle between the two output ports.	Phase at coupled port – Phase at transmission port

* P_{in} : power of input port , P_{out} : power of output port , P_{cou} : power of output port ,
 P_{iso} : power of isolated port , P_{back} : Return power of input port

5. Test Methode

1. Calibrating your vector network analyzer.
2. Connect the VNA 4 Port to DUT respectively
3. Measure the data of coupling through port 1 to port 4(S41).
4. Measure the data of transmission through port 1 to port 3(S31).
5. Measure the data of isolation through port 1 to port 2(S21).
6. Measure the data of phase port 4 & port 3(port 1 feeding).
7. Measure the data of return loss port 1, port 2, port 3 & port 4.
8. According to the above data to calculate insertion loss, amplitude balance & phase.

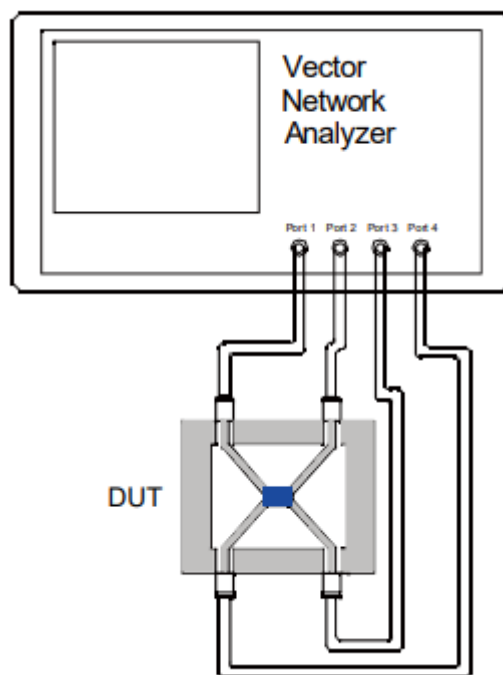

6. Soldering (Reflow soldering)

6.1. PCB pattern design condition (recommended)

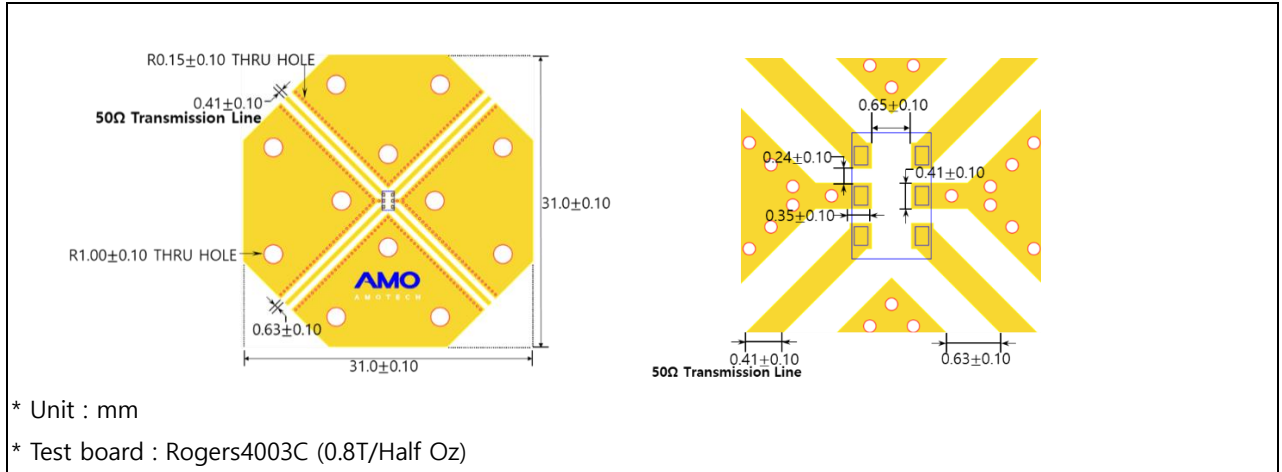

6.2. Soldering condition

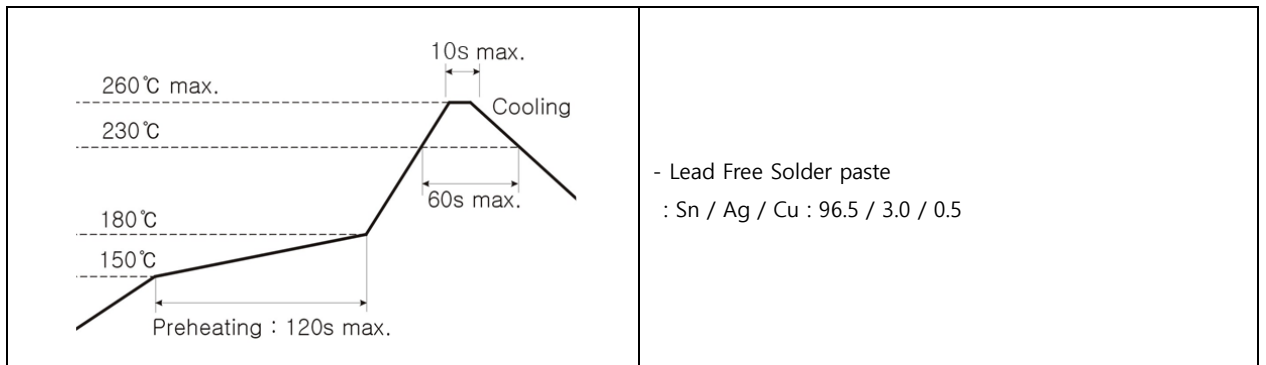

Follow the recommended soldering conditions to avoid degradation of performance .

- This product is designed for reflow soldering only. Do not use flow soldering.
- Use non-activated flux. (Max. Cl content less than 0.2%)
- Reflow cycle times should be done less than 3 times.

7. Caution

- 1) Storage environment : -5~40°C temperature, 20~70% humidity (MSL Level 1)
- 2) Do not use in high temperature/high humidity and a corrosive atmosphere like sulfide, chloride gas which could damage the solderability.
- 3) Do not expose to mechanical shock to avoid crack.
- 4) Use chips within 6 months. If over 6 months, check solderability before use.

8. Packaging specification

8.1 Carrier tape Specification

8.1.1. Size

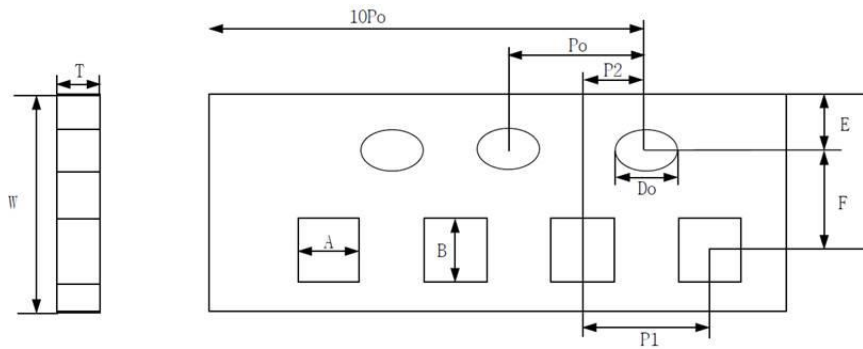

Unit: mm

	T	W	A	B	E	F	DO	*P1	*P2	PO	10PO
SPEC	0.98	8.0	1.55	2.30	1.75	3.50	1.55	4.00	2.00	4.00	40.00
Tolerance	±0.05	±0.1	±0.05	±0.05	±0.05	±0.05	±0.05	±0.1	±0.05	±0.1	±0.2

8.1.2. Chip Locations

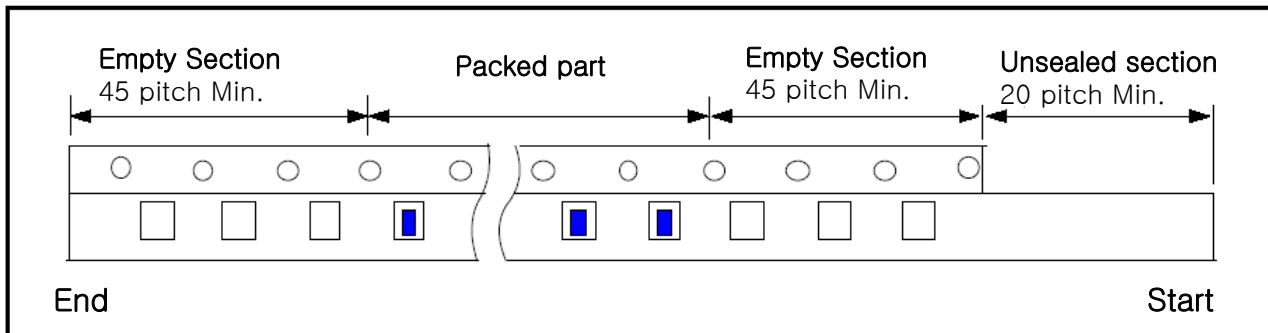

8.1.3. Material

- 1) Pater carrier tape : Laminated virgin pulp
- 2) Top tape : Polyester film
- 3) Bottom tape : Adhesive coated paper

8.2. Reel Specification

8.2.1. Size

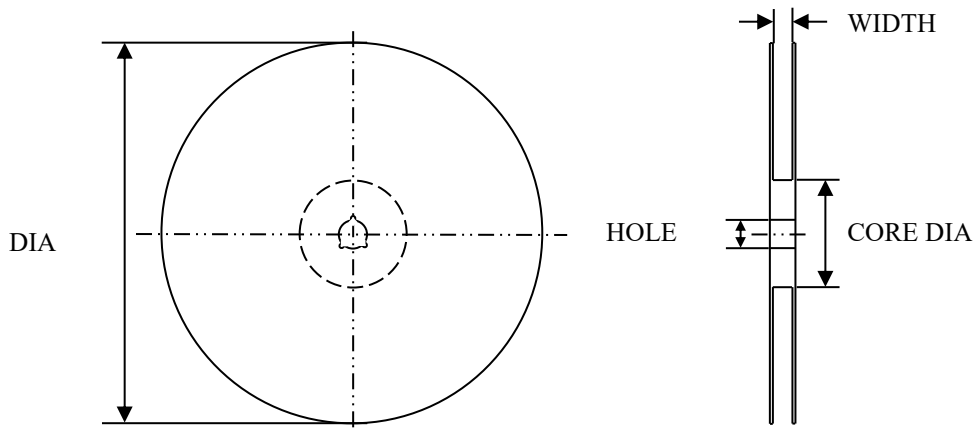

Item	DIA	WIDTH	CORE DIA	HOLE
Size (mm)	178.0±0.5	9.0±0.5	60.0±1.0	13.2±0.3

8.2.2. Label adherence and winding direction

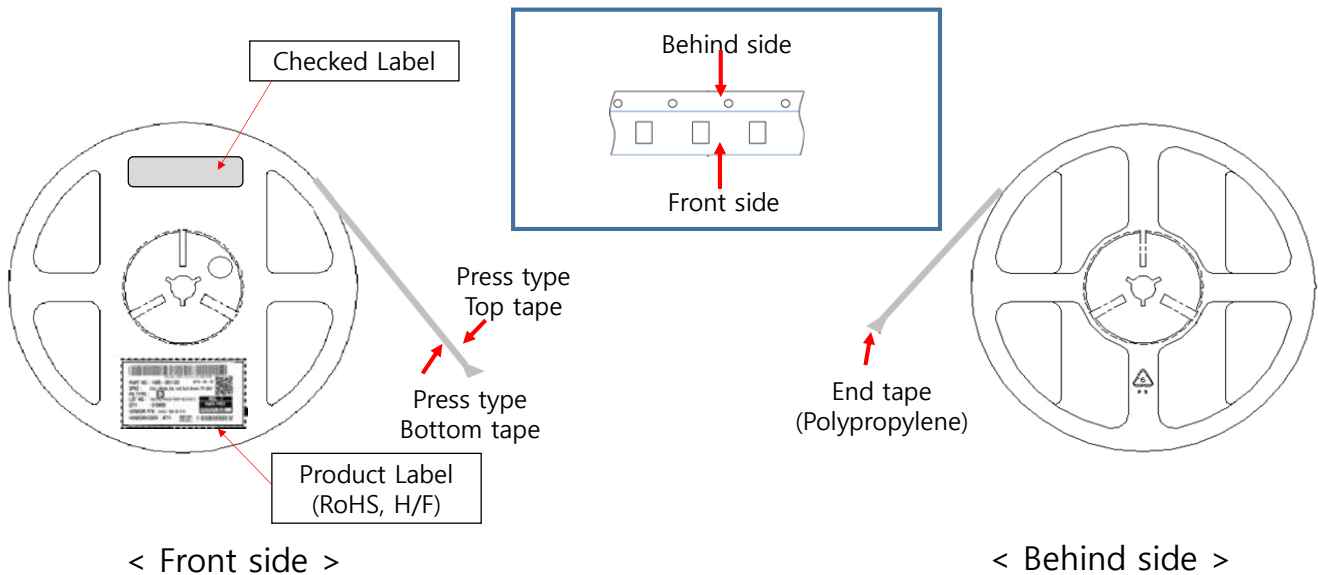

8.2.3. Material

- Plastic reel : GPS(General Purpose Styrene)

	DATASHEET	Part No.
	90-Degree Hybrid Coupler	CXH 03 T 3337 AA

8.3 Packaging Specification

EIA CODE (inch)	JIS CODE (mm)	Thickness typ. (mm)	Quantity (EA) / Reel	Quantity / Polybag
			7"/180mm (Material)	
0805	2.0x1.2	0.7	4,000 (Paper)	-

a) Reel packing

- ① 5 Reels per Inner box (13" Reel)
- ② 10 Inner boxes per Out box

b) Box type



(Inner Box)



(Out box)