	DATASHEET	Part No.
	Components Directional Couplers	CXD 20 T 3150 BG

CUSTOMER : _____

DATA SHEET

Product Name : Components Directional Couplers – Uneven coupler
Part No : CXD 20 T 3150 BG
Customer Code :

	MAKER	Location	TEL.	ADDRESS
	Office(Korea) Manufacture	Incheon	TEL) 82-32-821-0363 FAX) 82-32-811-0283	(21629) 5BL-1Lot, Namdongsearo 380, Namdong-Gu, Incheon, KOREA
	Homepage(URL)	http://www.amotech.co.kr		

1. Parts description

1.1. Overview

The CXD Series is a low cost, low profile sub-miniature high performance 20 dB coupler in an easy to use surface mount package. LTCC (Low Temperature Co-fired Ceramic), high conductivity metal conductor (Ag), and gold (Au) plating enable the CXH Series to minimize insertion loss and improve durability for thermal stabilization and electricity. The CXD Series is offered in a variety of frequency bands compatible with various types of high frequency wireless systems.

1.2. Features

- 3100 ~ 5000MHz
- Mean Coupling 20dB
- Low Insertion Loss
- Surface mount type
- LTCC base (Er=4.6)
- RoHS Compliance (Pb Free)

1.3. Applications

- Balanced Amplifiers and Signal Distribution in Wireless Communications
- LTE, WiMax and WiBro
- Base station and Repeater
- SUB-6



DATASHEET

Part No.

Components Directional Couplers

CXD 20 T 3150 BG

2. Model and Lot Number description

2.1. Model

<u>CXD</u>	<u>20</u>	<u>T</u>	<u>3150</u>	<u>BG</u>
(1)	(2)	(3)	(4)	(5)

- (1) Series name
- (2) Coupling (dB) : Mean Coupling 20dB
- (3) Chip Size : "T" – 0805inch (2.04 x 1.29 mm)
- (4) Frequency Bandwidth: 3100MHz ~ 5000MHz
- (5) Design Code

3. Style and Dimension

3.1. Appearance and dimension

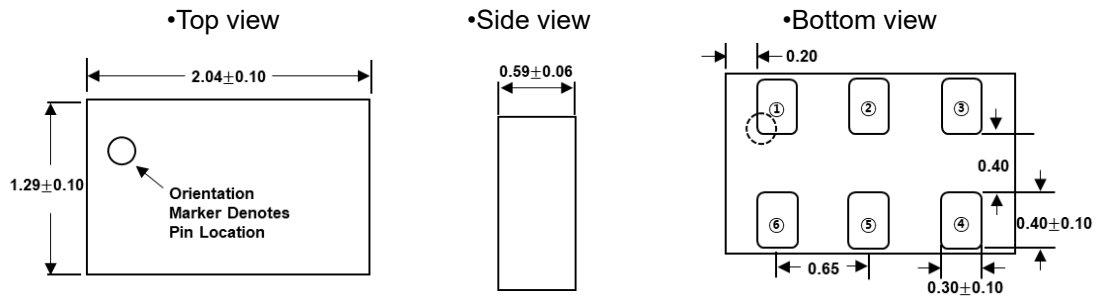

- **Unit : mm**
- **Tolerances are Non-Cumulative**

3.2. Pin Description

Pin	Case 1	Case 2
①	Input	Direct
②	GND	GND
③	Coupled	Isolated
④	Isolated	Coupled
⑤	GND	GND
⑥	Direct	Input

4. Specifications

4.1. Frequency characteristics

Frequency (MHz)	Coupling (dB)	Return Loss Min.(dB)	Insertion Loss Max.(dB)	Directivity Min.(dB)	Power Handling Avg.(W)	Operating Temperature(°C)
3100 ~ 3300	20.5±1.5	18	0.1	17	10	-55 ~ 125
3300 ~ 4200	20.2±1.5	18	0.1	18		
4200 ~ 4400	20.0±1.5	18	0.1	18		
4400 ~ 5000	20.2±1.5	18	0.1	18		

4.2. Definition of Measured Specifications

Parameter	Definition	Mathematical Representation
Coupling	At a given frequency coupling is the input power divided by the power at the coupled port. Coupling is the average values in the band.	$10\log(P_{cou} / P_{in})$
Return Loss	The impedance match of the coupler to a 50Ω System. Return Loss is an alternate mean to express VSWR.	$10\log(P_{in} / P_{back})$
Isolation	The input power divided by the power at the isolated port.	$10\log(P_{iso} / P_{in})$
Insertion Loss	The input power divided by the sum of the power at the two output port.	$10\log(P_{in} / (P_{cou} + P_{direct}))$
Transmission Loss	The input power divided by the power at the direct port.	$10\log(P_{direct} / P_{in})$
Directivity	The power at the isolated port divided by the power at the coupled port	$10\log(P_{iso} / P_{cou})$

* P_{in} : power of input port , P_{direct} : power of direct port , P_{cou} : power of coupled port ,

P_{iso} : power of isolated port , P_{back} : Return power of input port

4.3. Frequency characteristics

Typical Performance Performance : 3100MHz to 5000MHz (Case 1)

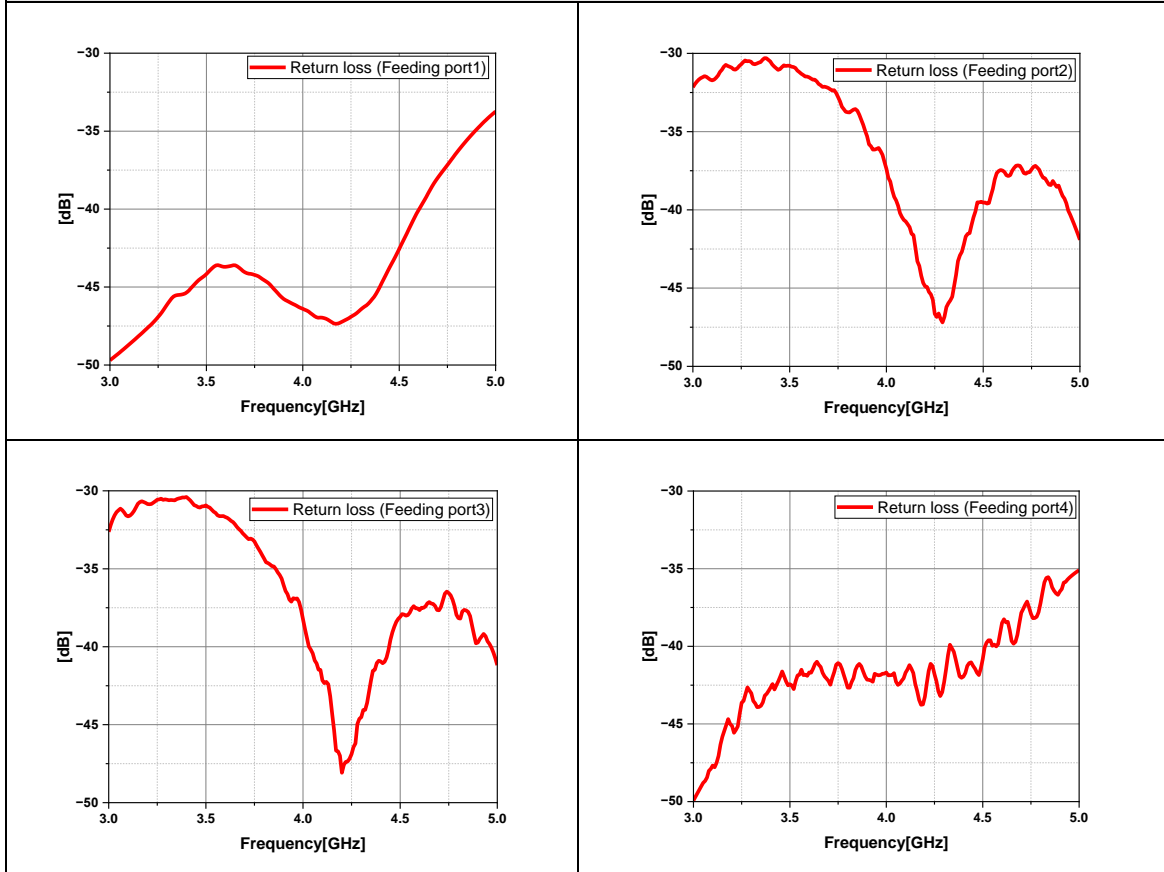

Typical Performance Performance : 3100MHz to 5000MHz (Case 1)

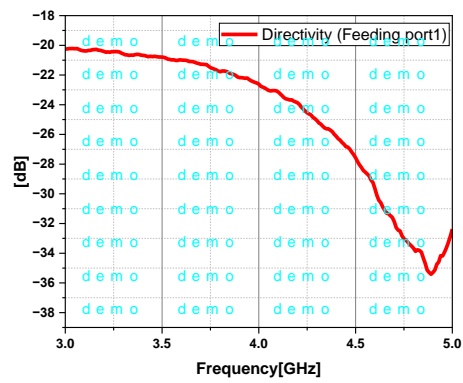
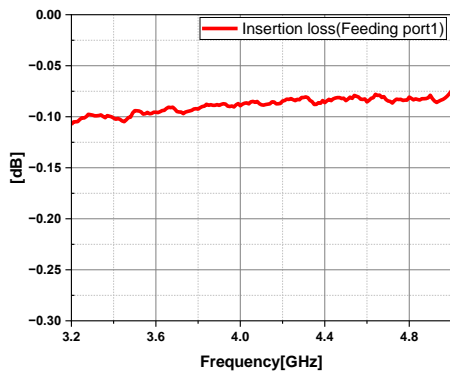
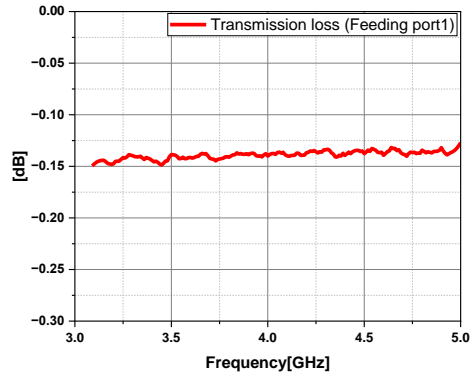
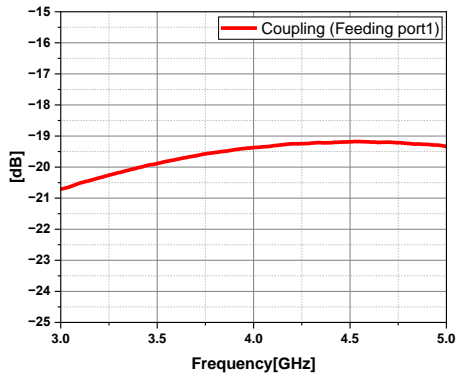

4.4 Power Derating Curve

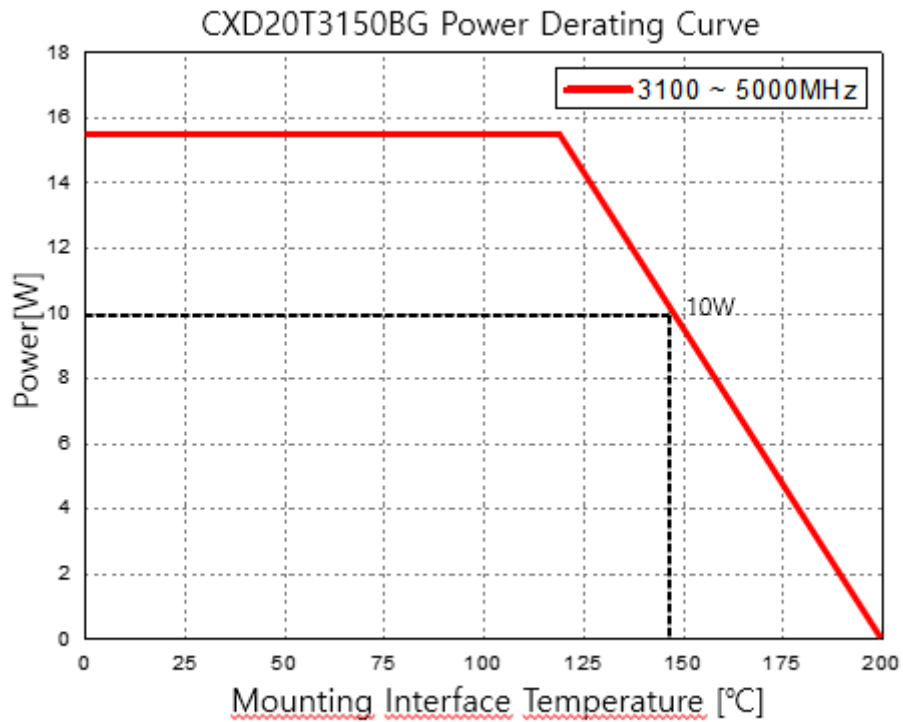

CXD20T3150BG power derating curve is shows the maximum allowable average power of the depending on base PCB temperature changes.

Following factors are determining the power derating curve.

- Internal Circuit Temperature
- Insertion Loss
- Material properties
- Operating temperature
- Mounting interface temperature

As the mounting interface temperature approaches the maximum continuous operating temperature,

the power handling decreases to zero.

5. Test Methode

1. Calibrating your vector network analyzer.
2. Connect the VNA 4 Port to DUT respectively
3. Measure the data of isolation through port 1 to port 4(S41).
4. Measure the data of coupling through port 1 to port 3(S31).
5. Measure the data of Transmission Loss through port 1 to port 2(S21).
6. Measure the data of phase port 4 & port 3(port 1 feeding).
7. Measure the data of return loss port 1, port 2, port 3 & port 4.
8. According to the above data to calculate insertion loss, directivity.

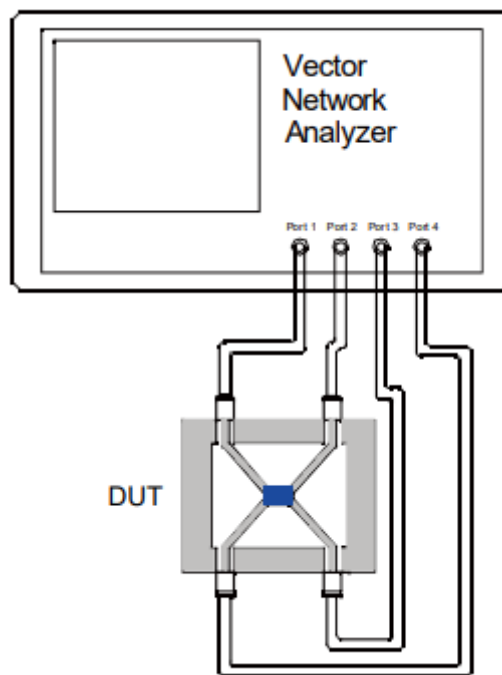

6. Soldering (Reflow soldering)

6.1. PCB pattern design condition (recommended)

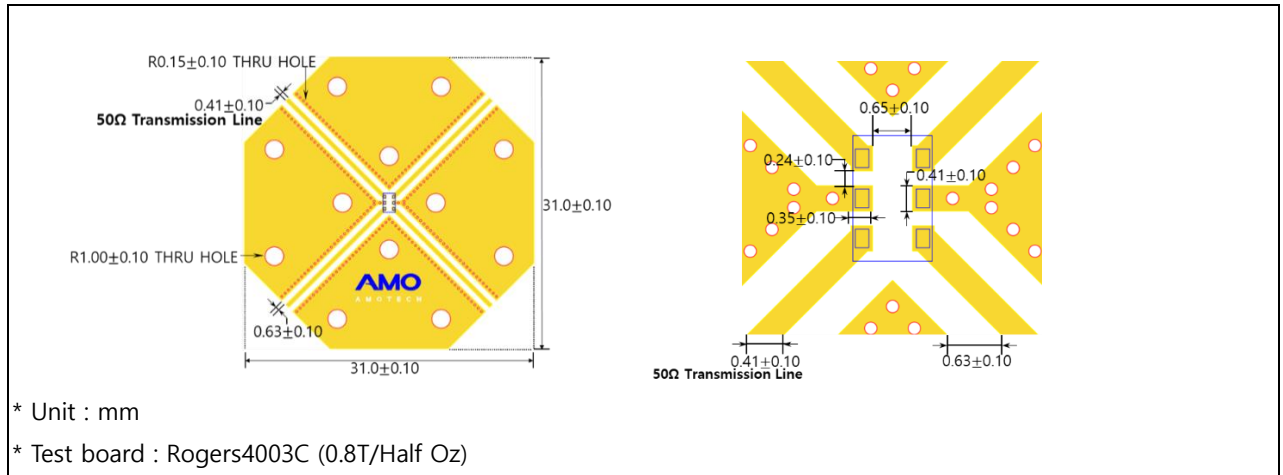

6.2. Soldering condition

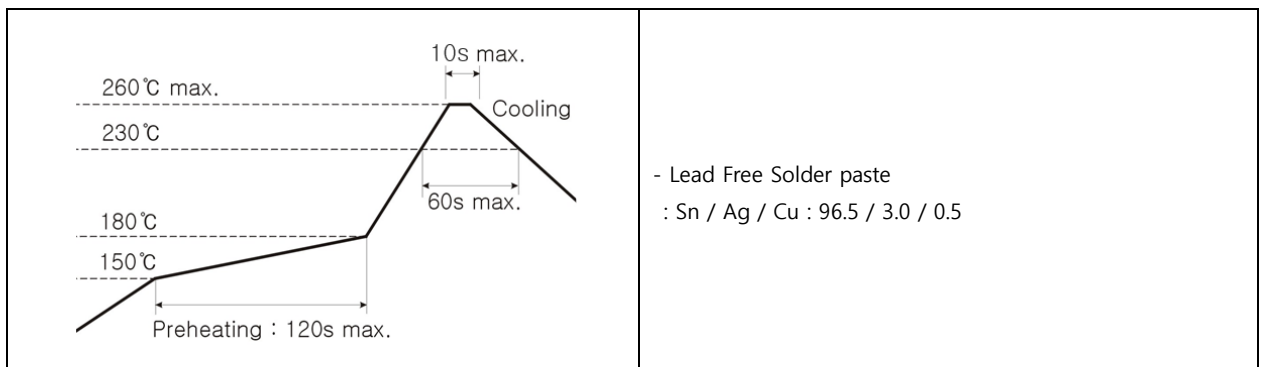

Follow the recommended soldering conditions to avoid degradation of performance .

- This product is designed for reflow soldering only. Do not use flow soldering.
- Use non-activated flux. (Max. Cl content less than 0.2%)
- Reflow cycle times should be done less than 3 times.

7. Caution

- 1) Storage environment : -5~40°C temperature, 20~70% humidity (MSL Level 1)
- 2) Do not use in high temperature/high humidity and a corrosive atmosphere like sulfide, chloride gas which could damage the solderability.
- 3) Do not expose to mechanical shock to avoid crack.

4) Use chips within 6 months. If over 6 months, check solderability before use.

8. Packaging specification

8.1 Carrier tape Specification

8.1.1. Size

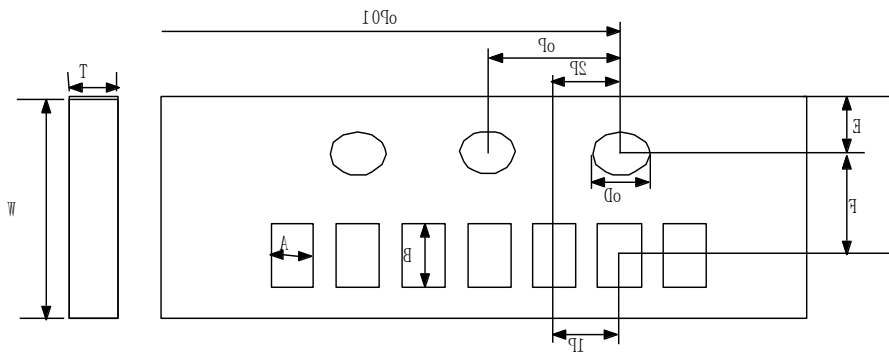

Unit: mm

	T	W	A	B	DO	F	P2	P1	E	PO	10PO
SPEC	0.75	8.00	1.55	2.30	1.55	3.50	2.00	4.00	1.75	4.00	40.00
Tolerance	±0.05	±0.10	±0.05	±0.05	±0.03	±0.05	±0.05	±0.10	±0.05	±0.10	±0.20

8.1.2. Material

- 1) Pater carrier tape : Laminated virgin pulp
- 2) Top tape : Polyester film
- 3) Bottom tape : Adhesive coated paper

8.2. Reel Specification

8.2.1. Size

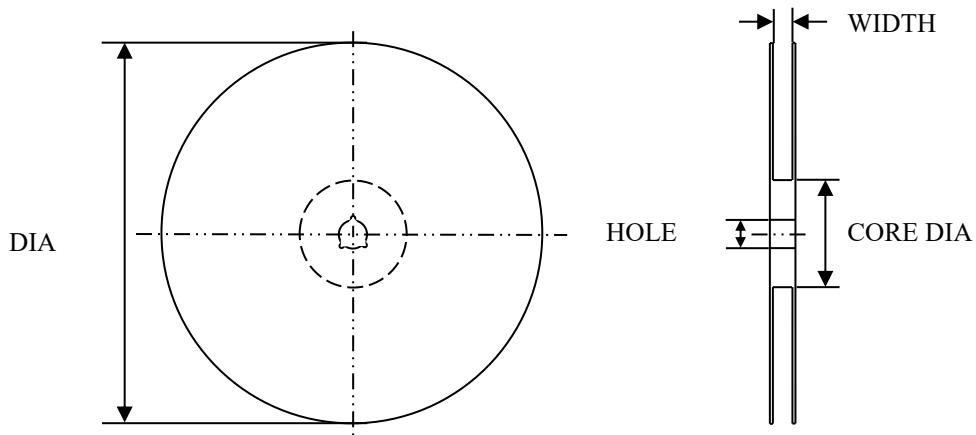

Item	DIA	WIDTH	CORE DIA	HOLE
Size (mm)	178.0±0.5	9.0±0.5	60.0±1.0	13.2±0.3

8.2.2. Label adherence and winding direction

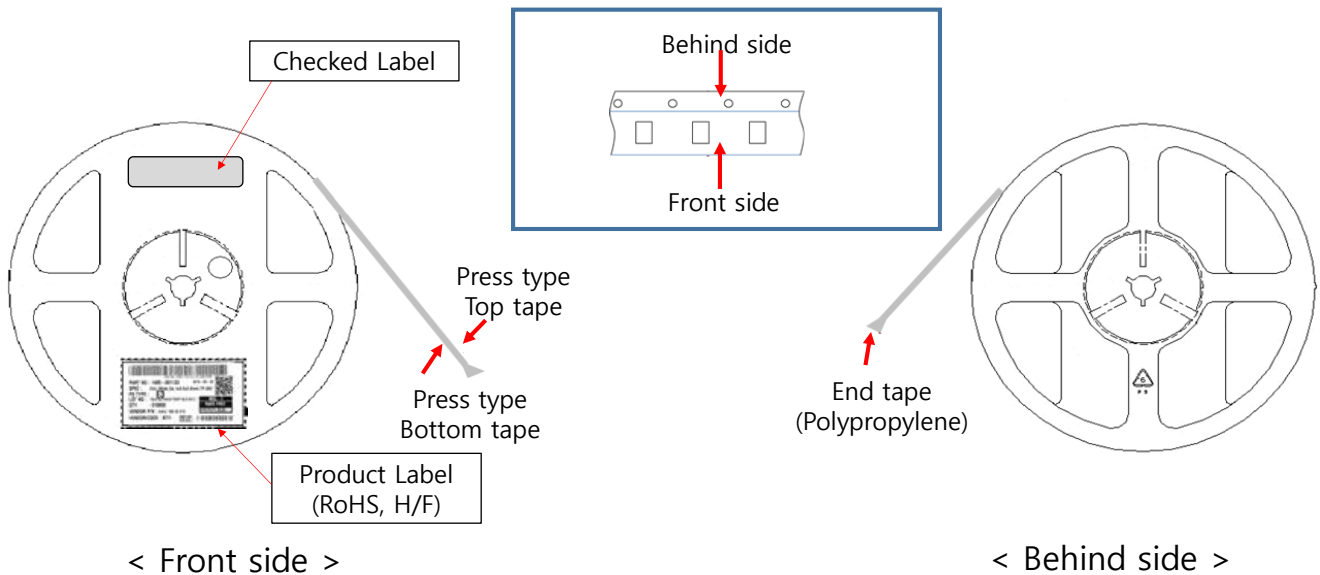

8.2.3. Material

- Plastic reel : GPS(General Purpose Styrene)

	DATASHEET	Part No.
	Components Directional Couplers	CXD 20 T 3150 BG

8.3 Box packaging Specification

Size (mm)	Thickness typ. (mm)	Quantity (EA) / Reel	Quantity
		7"/180mm (Material)	/ Polybag
2.04 x 1.29	0.59	4,000 (Paper)	
			-

a) Reel packing

- ① 5 Reels per Inner box (7" Reel)
- ② 10 Inner boxes per Out box

b) Box type



(Inner Box)

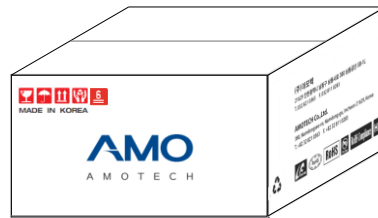

(Out box)