

**DATASHEET****Part No.****Components Directional Couplers****CXD 10 T 2337 AG**

CUSTOMER : _____

DATA SHEET

Product Name : Components Directional Couplers – Uneven coupler**Part No : CXD 10 T 2337 AG****Customer Code :** _____

	MAKER	Location	TEL.	ADDRESS
	Office(Korea) Manufacture	Incheon	TEL) 82-32-821-0363 FAX) 82-32-811-0283	(21629) 5BL-1Lot, Namdongsearo 380, Namdong-Gu, Incheon, KOREA
	Homepage(URL)	http://www.amotech.co.kr		

1. Parts description

1.1. Overview

The CXD Series is a low cost, low profile sub-miniature high performance 10 dB coupler in an easy to use surface mount package. LTCC (Low Temperature Co-fired Ceramic), high conductivity metal conductor (Ag), and gold (Au) plating enable the CXD Series to minimize insertion loss and improve durability for thermal stabilization and electricity. The CXD Series is offered in a variety of frequency bands compatible with various types of high frequency wireless systems.

1.2. Features

- 2300 ~ 3700MHz
- Mean Coupling 10dB
- Low Insertion Loss
- Surface mount type
- LTCC base (Er=4.6)
- RoHS Compliance (Pb Free)

1.3. Applications

- Balanced Amplifiers and Signal Distribution in Wireless Communications
- LTE, WiMax and WiBro
- Base station and Repeater



DATASHEET

Part No.

Components Directional Couplers

CXD 10 T 2337 AG

2. Model and Lot Number description

2.1. Model

<u>CXH</u>	<u>10</u>	<u>T</u>	<u>2337</u>	<u>AG</u>
(1)	(2)	(3)	(4)	(5)

- (1) Series name
- (2) Coupling (dB)
- (3) Chip Size : "T" – 0805inch (2.0 x 1.2 mm)
- (4) Frequency Bandwidth
- (5) Design Code

3. Style and Dimension

3.1. Appearance and dimension

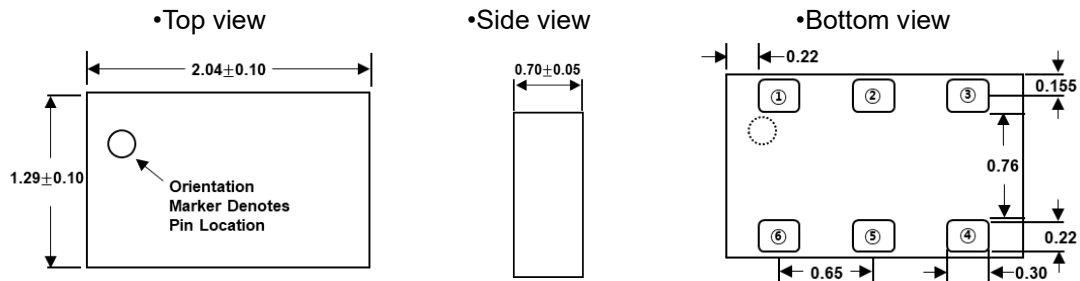

- **Unit : mm**
- **Tolerances are Non-Cumulative**

3.2. Pin Description

Pin	Case 1	Case 2
①	Input	Direct
②	Coupled	Isolated
③	GND	GND
④	GND	GND
⑤	Isolation	Coupling
⑥	Direct	Input

4. Specifications

4.1. Frequency characteristics

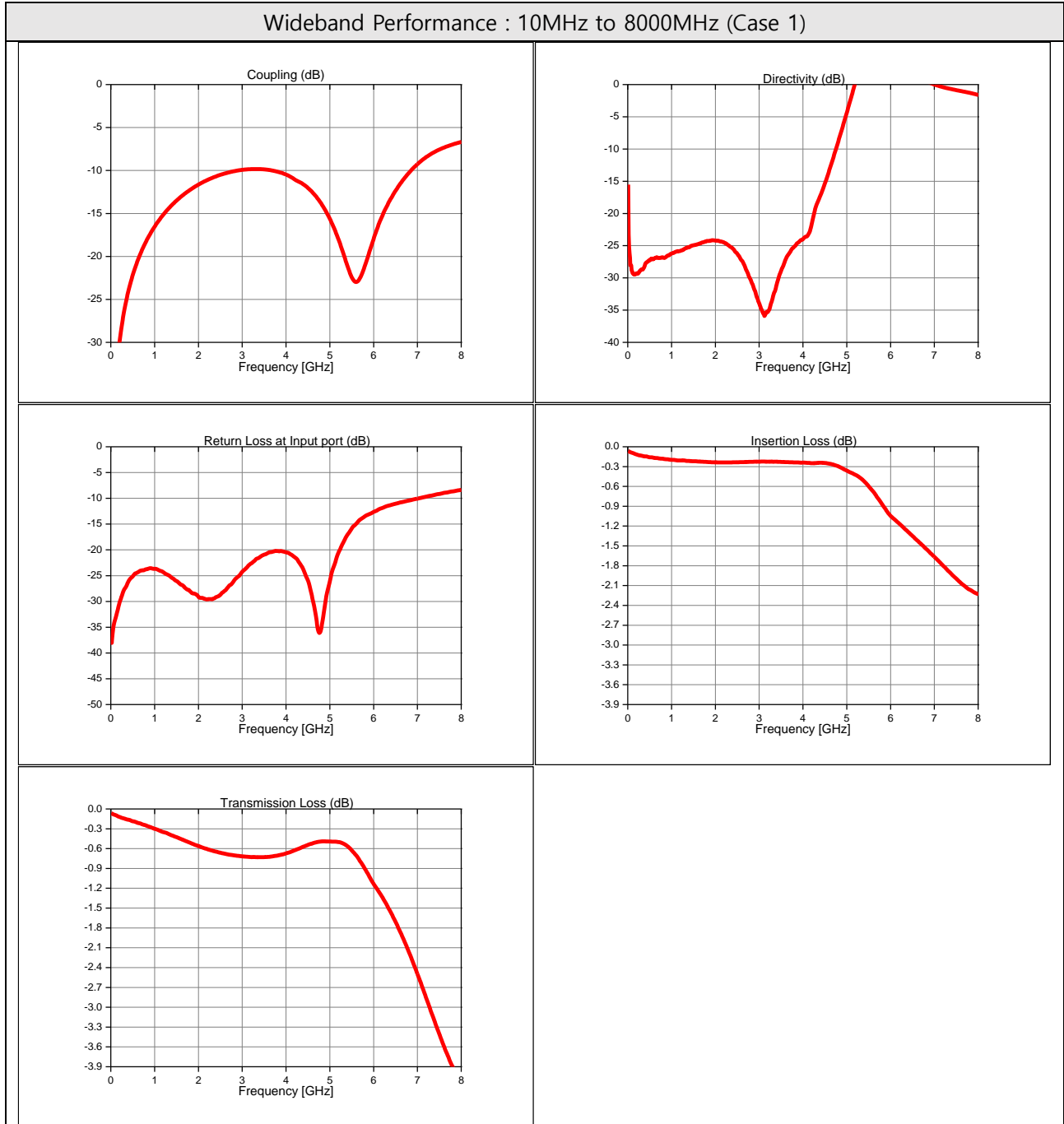

Typical Performance : 2200MHz to 3800MHz (Case 1)

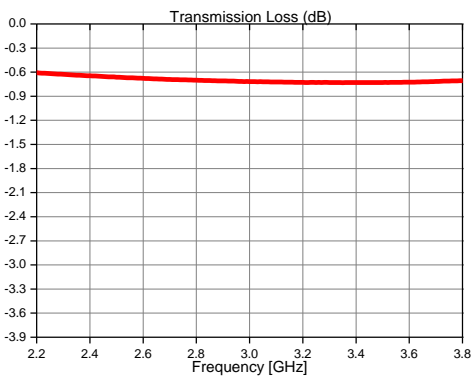
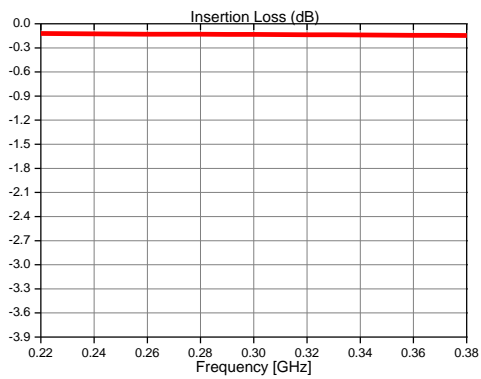
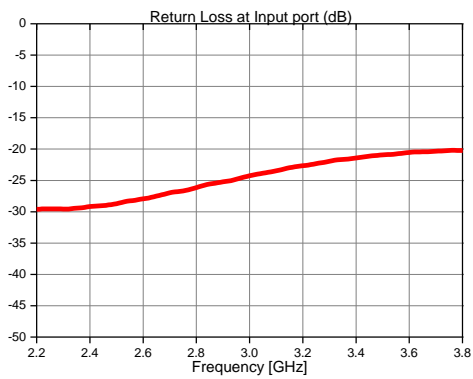
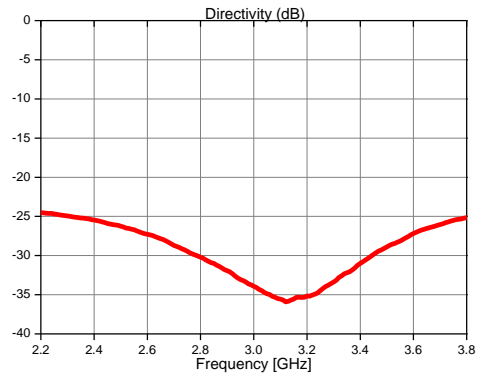
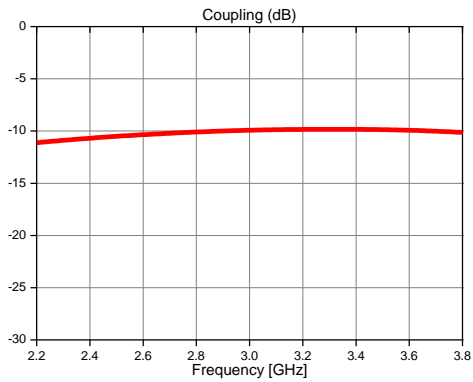

4.2. Electrical characteristics

Frequency (MHz)	Coupling (dB)	Return Loss Min.(dB)	Insertion Loss Max.(dB)	Directivity Min.(dB)	Power Handling Avg.(W)	Operating Temperature(°C)
2300 ~ 2400	10.5±1.0	29	0.14	25	2	-55 ~ 125
2400 ~ 2500	10.0±1.0	28	0.14	25	2	
2630 ~ 2655	10.0±1.0	27	0.14	27	2	
3300 ~ 3700	10.0±1.0	20	0.14	25	2	

4.3. Definition of Measured Specifications

Parameter	Definition	Mathematical Representation
Coupling	At a given frequency coupling is the input power divided by the power at the coupled port. Coupling is the average values in the band.	$10\log (P_{cou} / P_{in})$
Return Loss	The impedance match of the coupler to a 50Ω System. Return Loss is an alternate mean to express VSWR.	$10\log (P_{in} / P_{back})$
Insertion Loss	The input power divided by the sum of the power at the two output port.	$10\log (P_{in} / (P_{in} + P_{out}))$
Directivity	The power at the isolated port divided by the power at the coupled port	$10\log (P_{iso} / P_{cou})$
Transmission Loss	The input power divided by the power at the direct port.	$10\log (P_{out} / P_{in})$

* P_{in} : power of input port , P_{out} : power of output port , P_{cou} : power of output port ,
 P_{iso} : power of isolated port , P_{back} : Return power of input port

5. Test Methode

1. Calibrating your vector network analyzer.
2. Connect the VNA 4 Port to DUT respectively
3. Measure the data of transmission loss through port 1 to port 4(S41).
4. Measure the data of isolation through port 1 to port 3(S31).
5. Measure the data of coupling through port 1 to port 2(S21).
6. Measure the data of phase port 4 & port 2(port 1 feeding).
7. Measure the data of return loss port 1, port 2, port 3 & port 4.
8. According to the above data to calculate insertion loss, amplitude balance & phase.

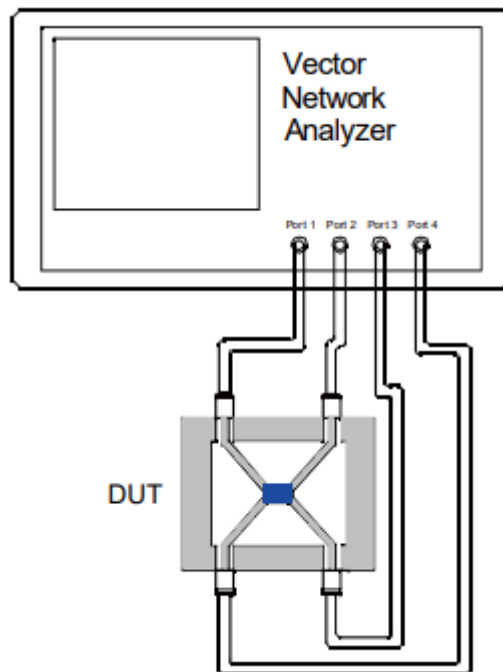

6. Soldering (Reflow soldering)

6.1. PCB pattern design condition (recommended)

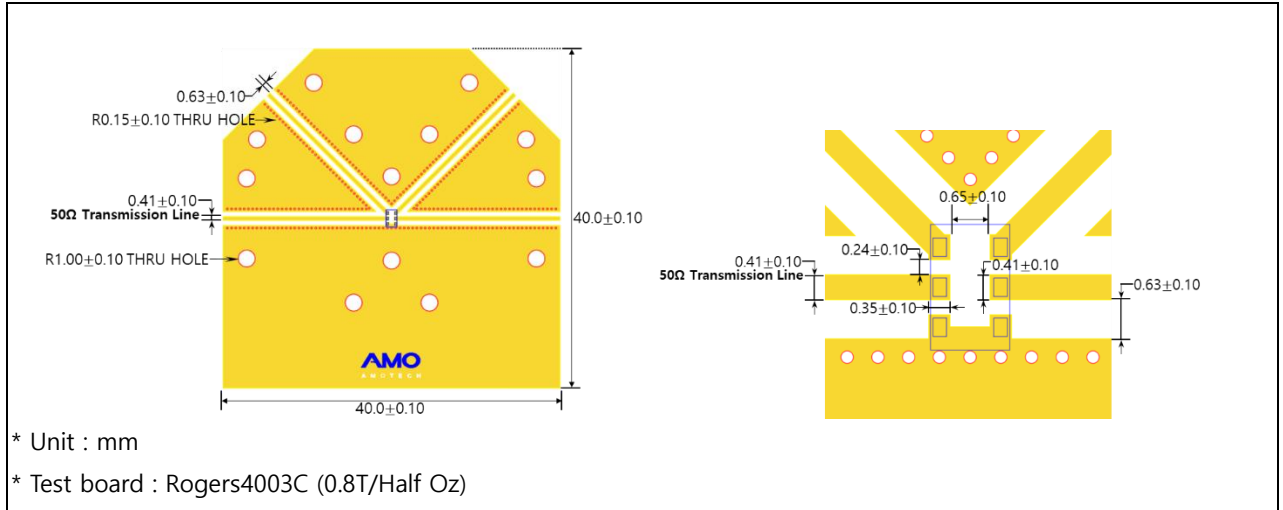

6.2. Soldering condition

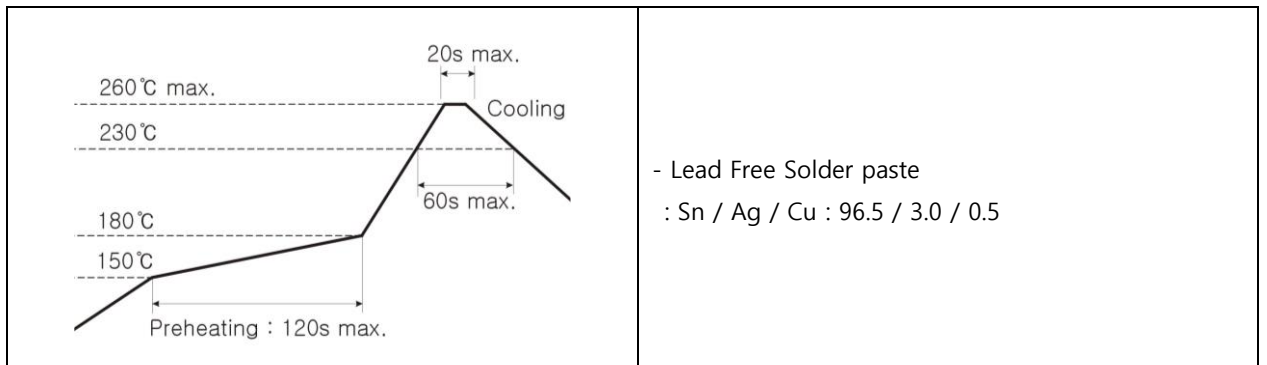

Follow the recommended soldering conditions to avoid degradation of performance .

- This product is designed for reflow soldering only. Do not use flow soldering.
- Use non-activated flux. (Max. Cl content less than 0.2%)
- Reflow cycle times should be done less than 3 times.

7. Caution

- 1) Storage environment : -5~40°C temperature, 20~70% humidity (MSL Level 1)
- 2) Do not use in high temperature/high humidity and a corrosive atmosphere like sulfide, chloride gas which could damage the solderability.
- 3) Do not expose to mechanical shock to avoid crack.
- 4) Use chips within 6 months. If over 6 months, check solderability before use.

8. Packaging specification

8.1 Carrier tape Specification

8.1.1. Size

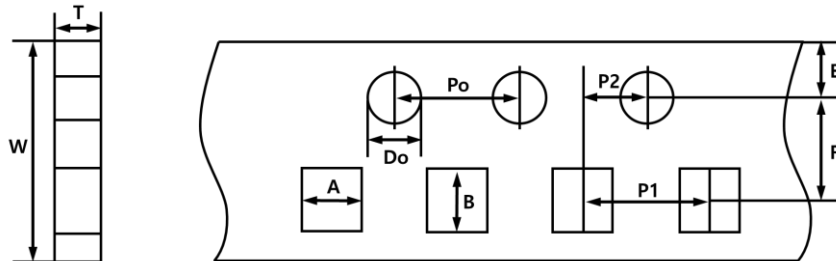

Unit: mm

	T	W	A	B	E	F	DO	*P1	*P2	PO	10PO
SPEC	<u>0.98</u>	8.0	1.55	2.30	1.75	3.50	1.55	4.00	2.00	4.00	40.00
Tolerance	±0.05	±0.1	±0.05	±0.05	±0.05	±0.05	±0.05	±0.1	±0.05	±0.1	±0.2

8.1.2. Chip Locations

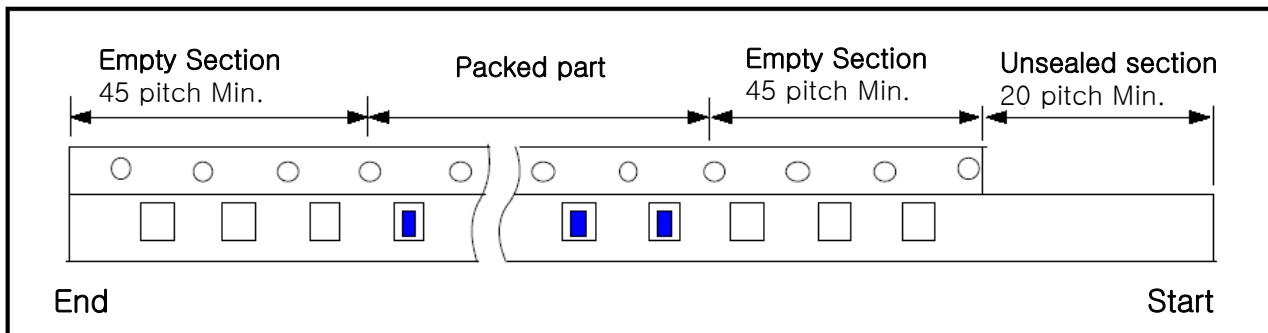

8.1.3. Material

- 1) Pater carrier tape : Laminated virgin pulp
- 2) Top tape : Polyester film
- 3) Bottom tape : Adhesive coated paper

8.2. Reel Specification

8.2.1. Size

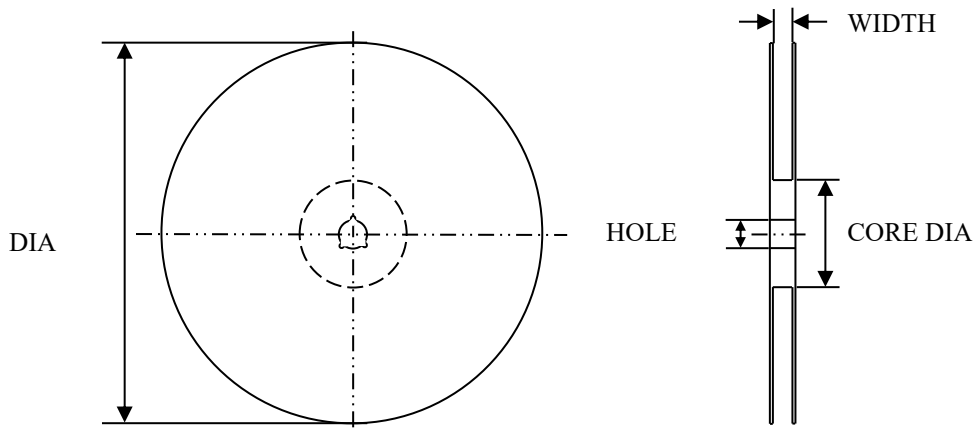

Item	DIA	WIDTH	CORE DIA	HOLE
Size (mm)	178.0±0.5	9.0±0.5	60.0±1.0	13.2±0.3

8.2.2. Label adherence and winding direction

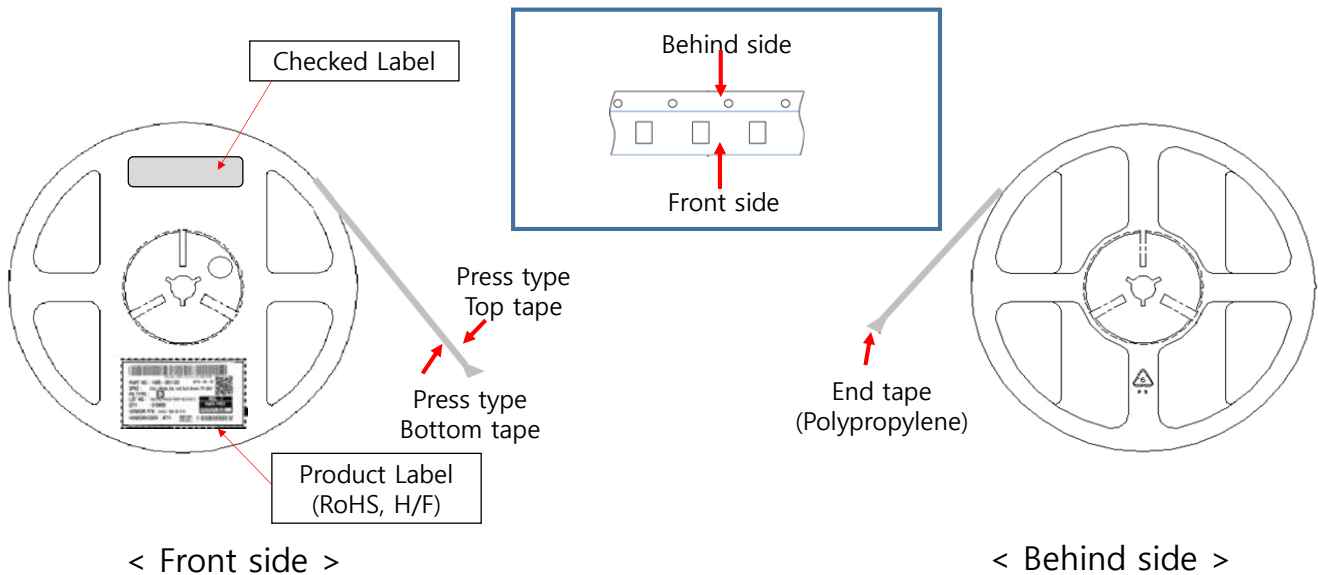



8.2.3. Material

- Plastic reel : GPS(General Purpose Styrene)

	DATASHEET	Part No.
	Components Directional Couplers	CXD 10 T 2337 AG

8.3 Box packaging Specification

Box	Small	Medium	Large
Size (mm)	183 (W) x 185 (D) x 70 (T)	200 (W) x 375 (D) x 205 (T)	375 (W) x 390 (D) x 205 (T)
Quantity	5 reels = 4,000 ea/reel x 5 = 20,000 ea	5 small boxes (25 reels) = 4,000 ea/reel X 25 = 100,000 ea	10 small boxes (50 reels) = 4,000 ea/reel X 50 = 200,000 ea
Detail			

8.4. Label Specification

Size : Reel & Small boxes : 80 X 40 (mm)

Medium & Large boxes : 100 X 100 (mm)